

ATOM X - RETROFITTABLE FIRE SUPPRESSION SYSTEM

FLUOROKETONE-FK (PRODUCT OVERVIEW)

The retrofittable ceiling-mounted Atom X is based on a clean agent, Fluoroketone, which is attached to the control panel. The system containers are attached to specially designed nozzles to ensure optimum use of the extinguishing agent. All modular units, once activated, discharge the agent at once, leading to total flooding. These modular units are attached to the control panel with detection devices together, forming a two-way communication with detection devices and agent containers. The detection devices detect even the weakest fire and send a signal to the control panel.

Atom X is available in Fluoroketone and applies to classes A, B, C, and Electrically started fires. At the same time, it comes in different sizes, which include 2 kg, 5 kg, 10 kg, and 15 kg.



ENGINEERING DRAWINGS

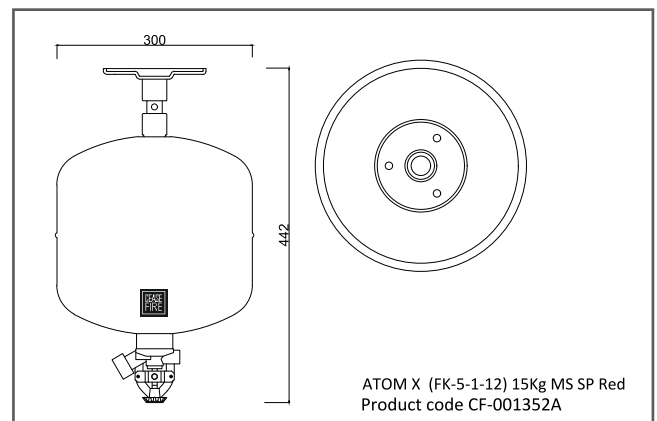
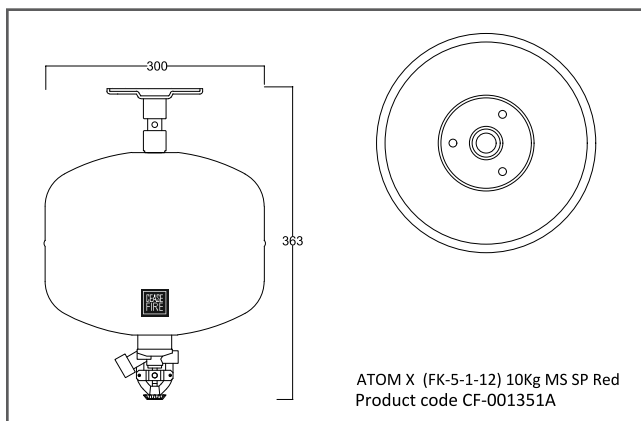
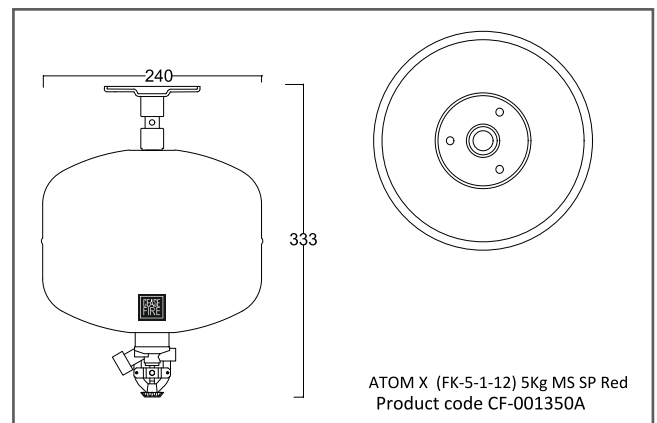
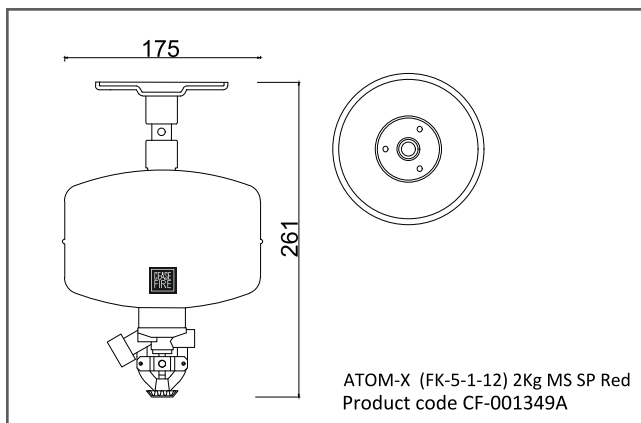



TECHNICAL SPECIFICATIONS

| Product Code | UOM | CF-001349A | CF-001350A | CF-001351A | CF-001352A |
|----------------------------------|-------|---|---|---|---|
| Description | — | ATOM-X (FK-5-1-12) 2Kg MS SP Red | ATOM-X (FK-5-1-12) 5Kg MS SP Red | ATOM-X (FK-5-1-12) 10Kg MS SP Red | ATOM-X (FK-5-1-12) 15Kg MS SP Red |
| Capacity of Agent | KG | 2-5% | 5-5% | 10-5% | 15-5% |
| Certification | — | PED BSI TESTED | PED BSI TESTED | PED BSI TESTED | PED BSI TESTED |
| Diameter of Shell | MM | 175 | 240 | 300 | 300 |
| Total Height (approx.) | MM | 261 | 333 | 363 | 442 |
| MOC of Shell | — | Steel CR2(DC01) | Steel CR2(DC01) | Steel CR2(DC01) | Steel CR2(DC01) |
| Mini. Wall Thickness | MM | 2 | 1.6 | 2 | 2 |
| Test Pressure | BAR | 35 | 35 | 35 | 35 |
| Anti Corrosive Treatment | — | Outer surfaces are EP Powder coated having Thickness 50 Micron Min. RAL Shade 3000 | Outer surfaces are EP Powder coated having Thickness 50 Micron Min. RAL Shade 3000 | Outer surfaces are EP Powder coated having Thickness 50 Micron Min. RAL Shade 3000 | Outer surfaces are EP Powder coated having Thickness 50 Micron Min. RAL Shade 3000 |
| Service Pressure | BAR | 10 | 10 | 10 | 10 |
| Type of Operating Mechanism | — | Automatic | Automatic | Automatic | Automatic |
| Type of Pressure Gauge | — | Magnetic Bourdon Tube Type | Magnetic Bourdon Tube Type | Magnetic Bourdon Tube Type | Magnetic Bourdon Tube Type |
| Type of Dis. Fitting & Length | MM | Thermal & Metron Actuator | Thermal & Metron Actuator | Thermal & Metron Actuator | Thermal & Metron Actuator |
| Throw | METER | NA | NA | NA | NA |

| Product Code | UOM | CF-001349A | CF-001350A | CF-001351A | CF-001352A |
|--------------------------------------|------|--|--|--|--|
| Min. Discharge Time | SEC. | up to 6 | 4 to 8 | 6 to 10 | 6 to 15 |
| Max. coverage Volume | Cu.M | 3 | 7.5 | 15 | 22.7 |
| Operating Temperature Range | °C | -30°C to +60°C | -30°C to +60°C | -30°C to +60°C | -30°C to +60°C |
| Applicable to Type of Fire | — | Class A, B,C & Electrical Started Fire | Class A, B,C & Electrical Started Fire | Class A, B,C & Electrical Started Fire | Class A, B,C & Electrical Started Fire |
| Filled Weight range | KG | 3.59 to 3.63 kg | 8.7 to 8.90 kg | 15.70 to 16 kg | 20.5 to 20.75 kg |
| Packed Weight range (Appr.) | KG | 5.41 | 10.14 | 18.14 | 25.42 |
| Packing Size Length X Width X Height | MM | 230 X 200 X 240 | 255 X 255 X 320 | 315 X 315 X 370 | 360 X 360 X 520 |
| Product Warranty | YEAR | 1 | 1 | 1 | 1 |

*It includes Empty Extinguisher, Contents, QBD , Metron and Base Plate.

*It includes Empty Extinguisher, Contents, Packaging, QBD , Metron and Base Plate.

CERTIFICATIONS



PRODUCT PICTURES



2 KG



5 KG



10 KG



15 KG

ATOM X - RETROFITTABLE FIRE SUPPRESSION SYSTEM

ABC POWDER-MAP 90 (PRODUCT OVERVIEW)

Understanding the evolving demands of unique infrastructures and businesses, Ceasefire presents the next generation of specialized fire suppression technology. Ceasefire Atom X doesn't demand any structural changes; neither consumes the floor space nor leads to downtime, as this innovative system is mounted on the ceiling of the space. Designed with smart and sensitive features, it minimizes the possibility of false activation and safeguards the premises. The system is an automated smart network of ceiling-mounted agent containers, an array of detection devices, and a control panel.

Atom X is available in MAP 90 and applies to classes A, B, C, and Electrically started fires. At the same time, it comes in different sizes, which include 2 kg, 5 kg, 10 kg, and 15 kg.



ENGINEERING DRAWINGS

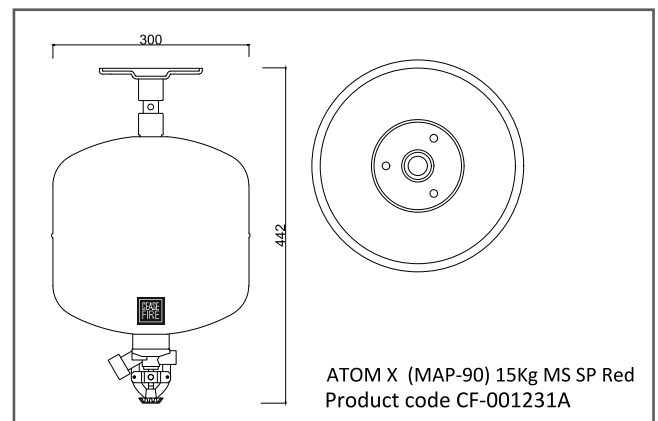
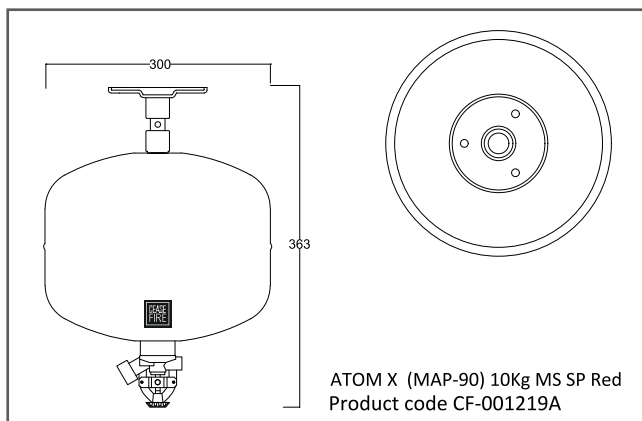
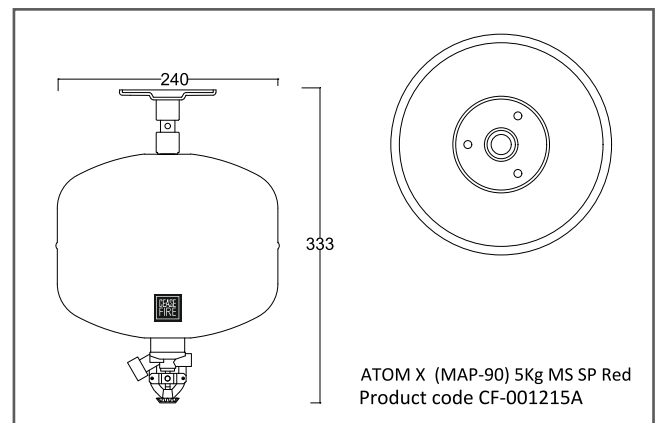
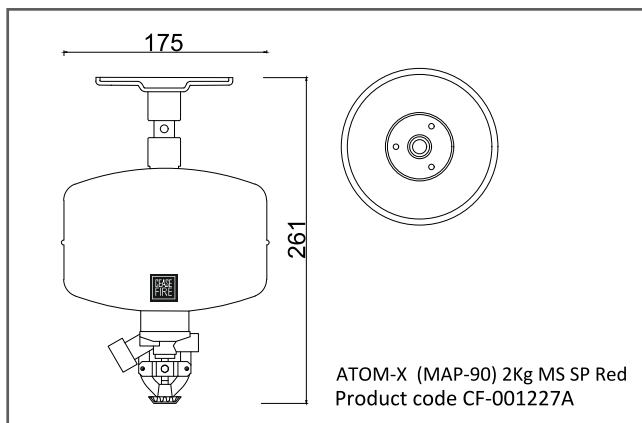



TECHNICAL SPECIFICATIONS

| Product Code | UOM | CF-001227A | CF-001215A | CF-001219A | CF-001231A |
|---|-------|--|--|--|--|
| Description | — | ATOM-X (MAP-90) 2Kg MS SP Red | ATOM-X (MAP-90) 5Kg MS SP Red | ATOM-X (FK-5-1-12) 10Kg MS SP Red | ATOM-X (MAP-90) 15Kg MS SP Red |
| Capacity of Agent | KG | 2 ± 3% | 5 ± 2% | 10 ± 2% | 15 ± 2% |
| Certification | — | PED BSI TESTED | PED BSI TESTED | PED BSI TESTED | PED BSI TESTED |
| Diameter of Shell | MM | 175 | 240 | 300 | 300 |
| Total Height (approx.) | MM | 261 | 333 | 363 | 442 |
| MOC of Shell | — | Steel CR2(DC01) | Steel CR2(DC01) | Steel CR2(DC01) | Steel CR2(DC01) |
| Mini. Wall Thickness | MM | 2 | 1.6 | 2 | 2 |
| Test Pressure | BAR | 35 | 35 | 35 | 35 |
| Anti Corrosive Treatment | — | Outer surfaces are EP Powder coated having Thickness 50 Micron Min. RAL Shade 3000 | Outer surfaces are EP Powder coated having Thickness 50 Micron Min. RAL Shade 3000 | Outer surfaces are EP Powder coated having Thickness 50 Micron Min. RAL Shade 3000 | Outer surfaces are EP Powder coated having Thickness 50 Micron Min. RAL Shade 3000 |
| Service Pressure | BAR | 15 | 15 | 15 | 15 |
| Type of Operating Mechanism | — | Automatic | Automatic | Automatic | Automatic |
| Type of Pressure Gauge | — | Magnetic Bourdon Tube Type | Magnetic Bourdon Tube Type | Magnetic Bourdon Tube Type | Magnetic Bourdon Tube Type |
| Type of Dis. Fitting & Length | MM | Thermal & Metron Actuator | Thermal & Metron Actuator | Thermal & Metron Actuator | Thermal & Metron Actuator |
| Throw | METER | NA | NA | NA | NA |
| Min. Discharge Time | SEC. | up to 6 | 4 to 8 | 6 to 10 | 6 to 15 |
| Max. coverage area at Ceiling Height 3.6m | Sq.m | 10 | 40 | 60 | 132 |

| Product Code | UOM | CF-001227A | CF-001215A | CF-001219A | CF-001231A |
|--------------------------------------|------|--|--|--|--|
| Operating Temperature Range | °C | -30°C to +60°C | -30°C to +60°C | -30°C to +60°C | -30°C to +60°C |
| Applicable to Type of Fire | — | Class A, B,C & Electrical Started Fire | Class A, B,C & Electrical Started Fire | Class A, B,C & Electrical Started Fire | Class A, B,C & Electrical Started Fire |
| Filled Weight range | KG | 3.59 to 3.63 | 8.70 to 8.90 | 15.70 to 16 | 20.50 to 20.75 |
| Packed Weight range (Appr.) | KG | 5.41 | 10.14 | 18.14 | 25.42 |
| Packing Size Length X Width X Height | MM | 230 X 200 X 240 | 255 X 255 X 320 | 315 X 315 X 370 | 360 X 360 X 520 |
| Product Warranty | YEAR | 1 | 1 | 1 | 1 |

*It includes Empty Extinguisher, Contents, QBD , Metron and Base Plate.

*It includes Empty Extinguisher, Contents, Packaging, QBD , Metron and Base Plate.

CERTIFICATIONS



PRODUCT PICTURES



*v1' Published Date is 31-07-2022.

**Regular R&D and product improvisations may lead to change in product specifications in this data sheet, without any prior notice.

CEASEFIRE INDUSTRIES UK LIMITED

Call us at: 0-113-868-6666, 0-126-891-9999

www.ceasefire.co.uk